

AUDIO-VISUAL COMMUNICATION MONITORING SYSTEM FOR ENHANCED SITUATIONAL AWARENESS

1



Durand R. Begault
Mark R. Anderson
Bryan U. McClain
Joel D. Miller
Elizabeth M. Wenzel

Human Factors Research & Technology Division

Advanced Controls and Displays Lab

NASA Ames Research Center

Moffett Field, California 94035-1000

Mail Stop 262-2 Room: 194

Tel (650) 604-3920

Email: dbegault@mail.arc.nasa.gov



ABSTRACT

The NASA-Ames Advanced Controls and Displays Laboratory has developed a Multi-modal Communications Display prototype (**HELMET CAM 3-D Audio Display**) for use in operations control applications that involve monitoring multiple communications channels and coordination between multiple agents, both human and robotic. The software-based system runs on a PC and is currently configured to **spatially render four simultaneous audio channels**, combined with simultaneous visual information from four video streams. The channels are spatially separated in virtual auditory space in order to **enhance speech intelligibility**, provide **direct representation of spatial location**, to allow **prioritization** of information, and **reduce operator fatigue**.

BACKGROUND

In a operations control application that involves the monitoring of multiple communications channels, effective communication is essential for relaying important and vital information.

Effective communication is defined as any form of communication where there is no degradation of information (i.e. speech and visual) between the sender and receiver.

In order to increase the effectiveness of communication, two things need to happen. An analysis of how the current system functions needs to be conducted in order to locate its deficiencies. Also, new and improved technologies need to be implemented and tested for use with rescue teams.

REQUIREMENTS FOR RESCUE COMMUNICATION SYSTEMS

Federal Regulations



“Authorized entrants must maintain contact with the attendant . Two way communication in combination with voice or alarms is recommended as effective communication.”

“Attendants must maintain effective communication with all authorized entrants during the entire entry.”

These requirements ensure that the attendant has the capability to inform rescue personnel of an evacuation if necessary.

EFFECTIVE COMMUNICATION IS IMPORTANT!

5

The 9-11 commission report on the World Trade Center attacks of September 11, 2001 reported that communication in general was a major problem during response to the disaster.

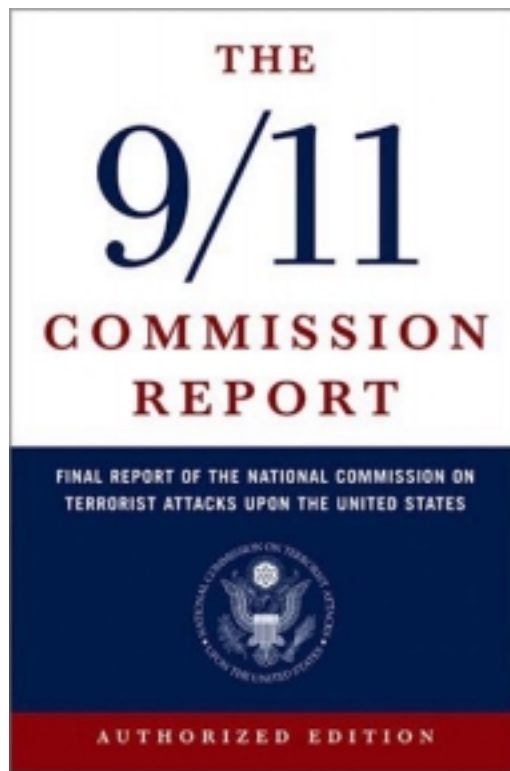

The commission stated, “*Almost all aspects of communications continue to be problematic, from initial notification to tactical operations.*” Because of this, many emergency responders had difficulty communicating information that was vital to rescue efforts.

PROBLEMS WITH THE CURRENT RESCUE SYSTEM

6

Because the current rescue systems are built in such a way that all personnel are speaking on the same channel at the same time, confusion and “bottlenecks” in the dialogue appear. This makes it difficult to communicate important information.



In addition, the current rescue systems do not provide video feedback from the rescuers. This means that rescue personnel are required to verbally describe what they see in a disaster area.

THE HELMET CAMERA SYSTEM FEATURES

The Helmet Camera is an integrated audio-video system designed specifically for improving the safety and efficiency of control center communications in search and rescue operations.

Audio and video from multiple channels, is formatted for optimal presentation to a control center operator, using **advanced spatialized audio techniques** and an interactive video display.

Front and Center technology- Channels can be **selectively 'prioritized'** while allowing the operator to simultaneously monitor other channels using an optimized 'party line' display.

Orientation and critical data from each rescuer (e.g., breathing rate) can also be displayed.

BASIC HELMET CAMERA SYSTEM OVERVIEW

8

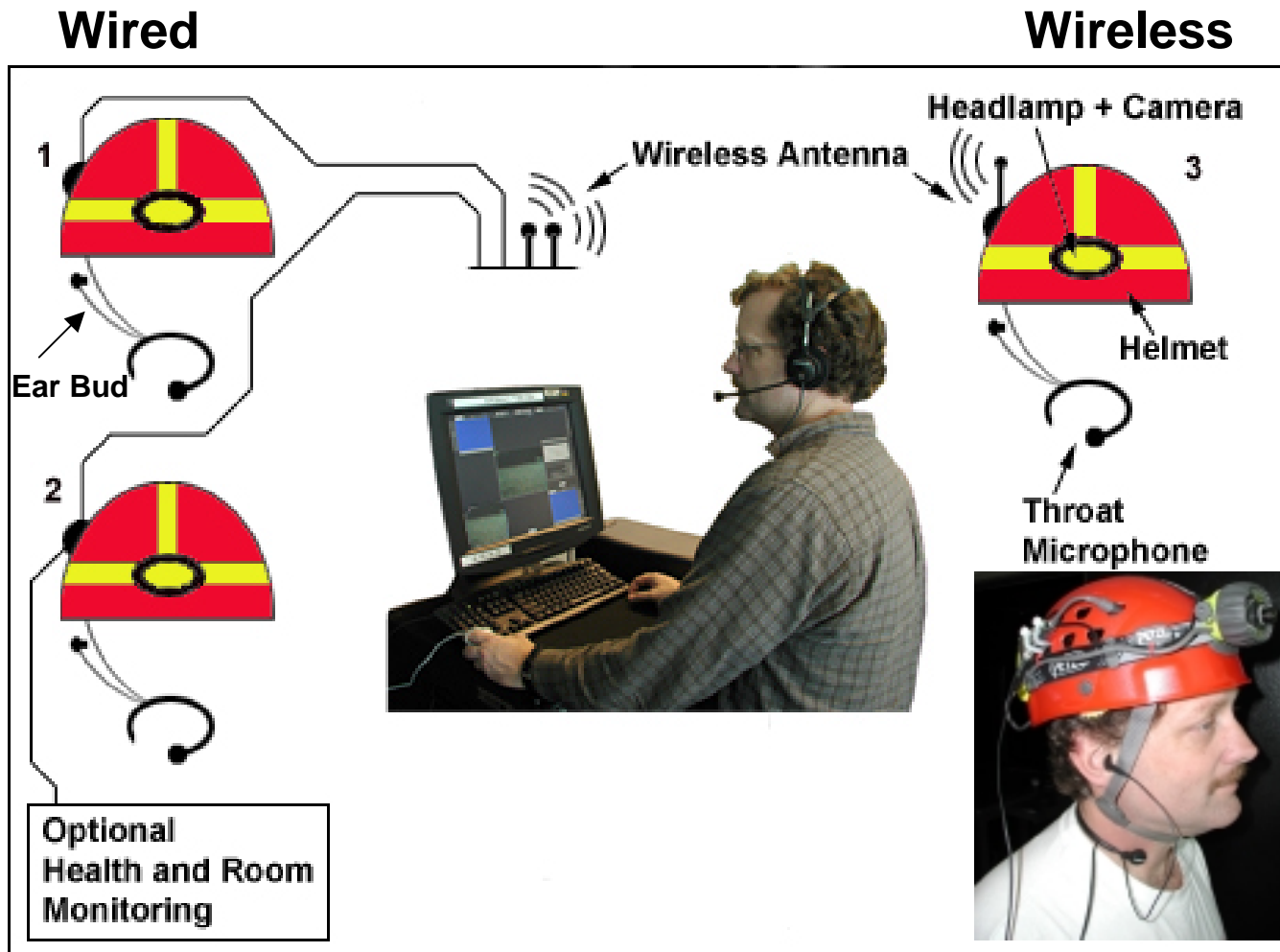

Four Channel Input to Central Station

“Party Line” Monitoring for each Rescuer

THE HELMET CAMERA ON RESCUER

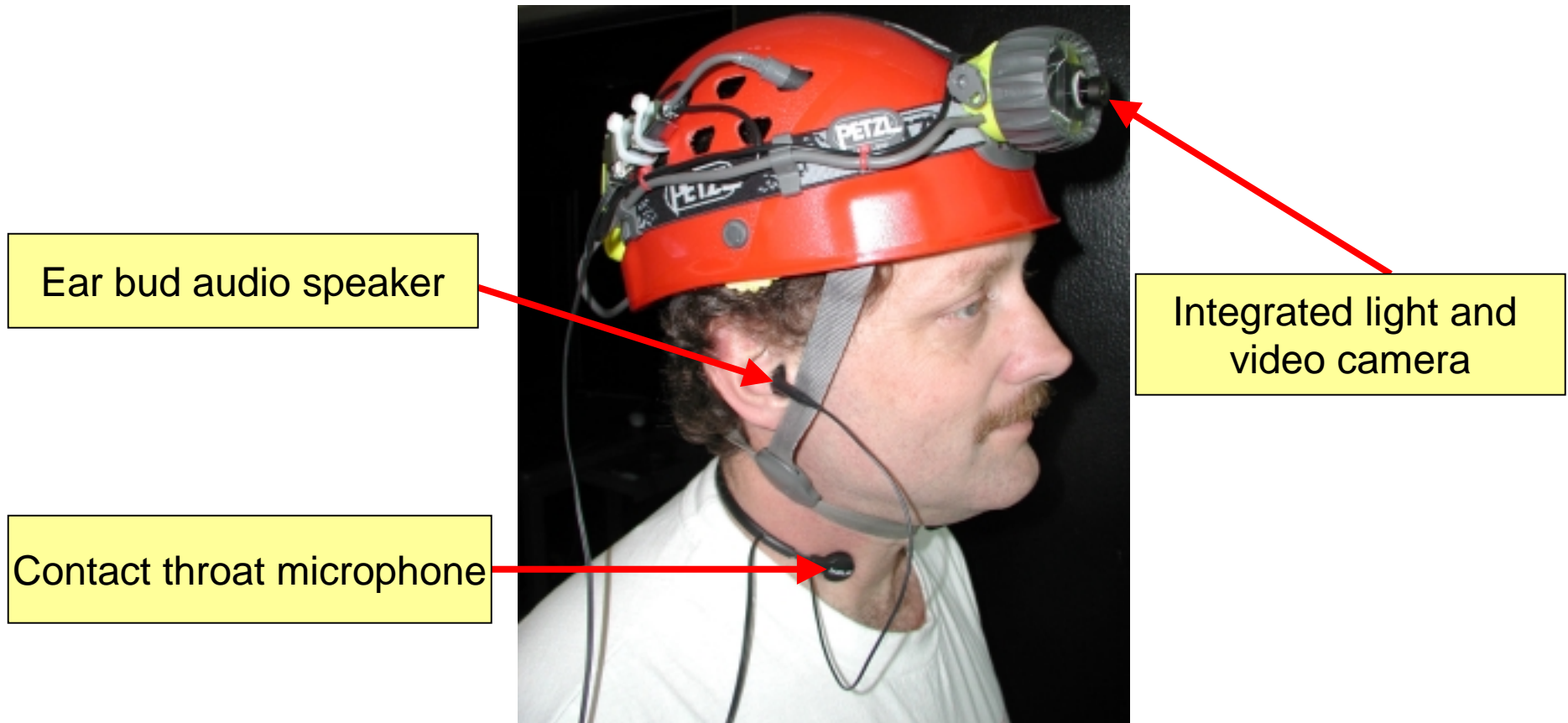

** Lightweight and Portable*

THE HELMET CAMERA 3-D DISPLAY

Communication
Link for Rescuers

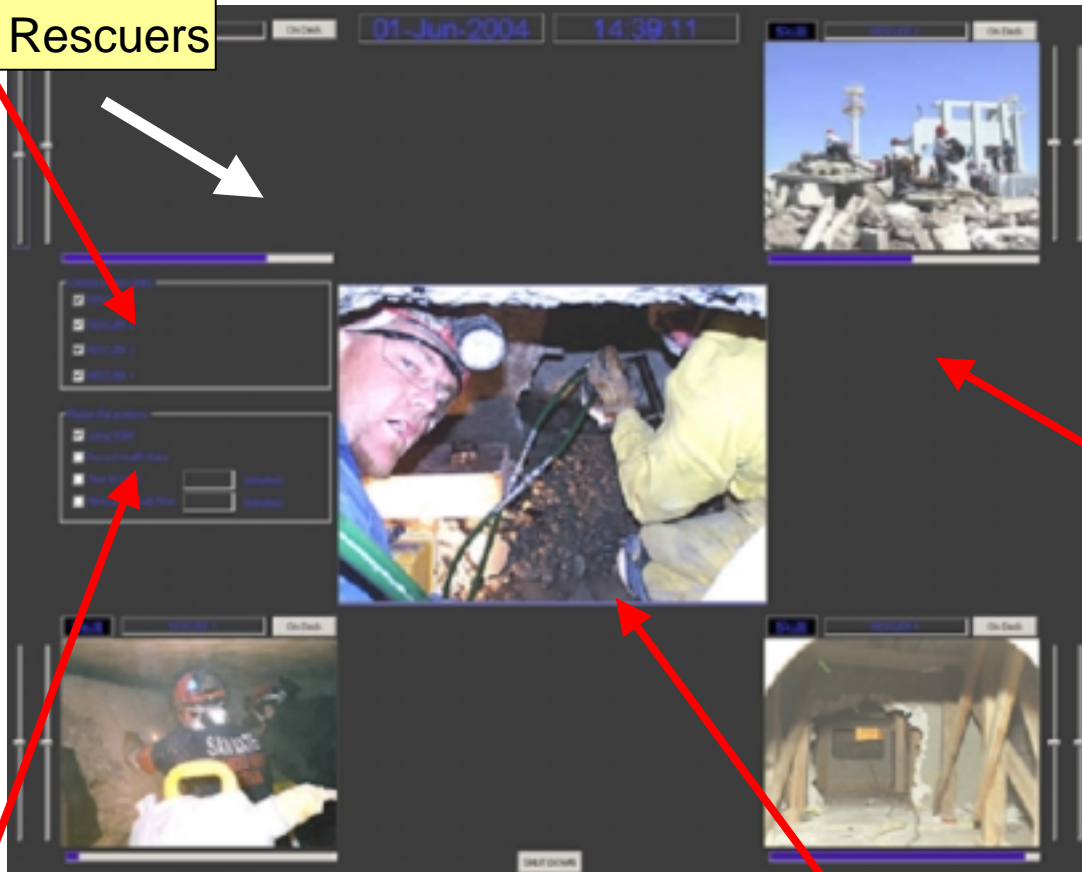

Scene Commander

Monitoring Features:
SCBA, Health,
Time Recording, and Orientation

Front and Center
Communication

FRONT AND CENTER PRIORITIZATION

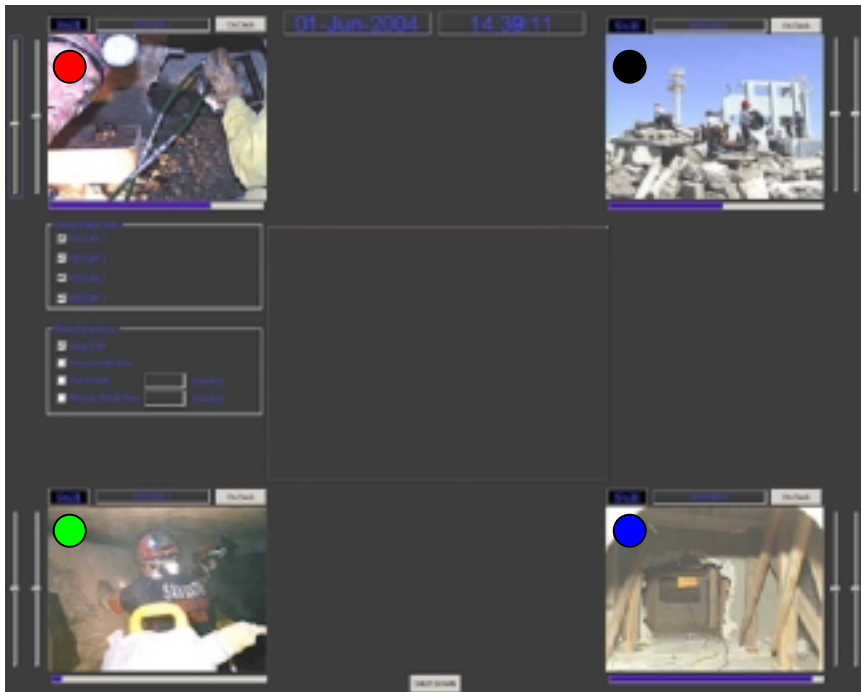
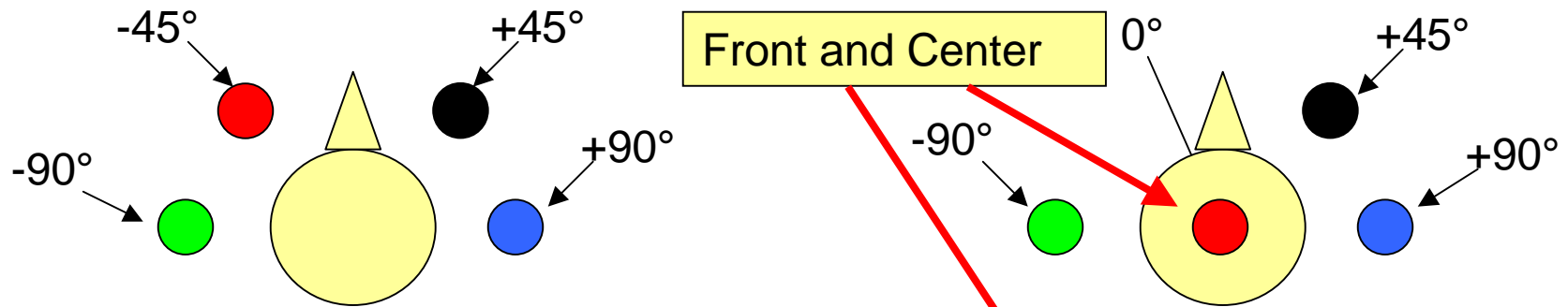

HELMET CAMERA 3-D PRIMARY COMMUNICATION DIAGRAM

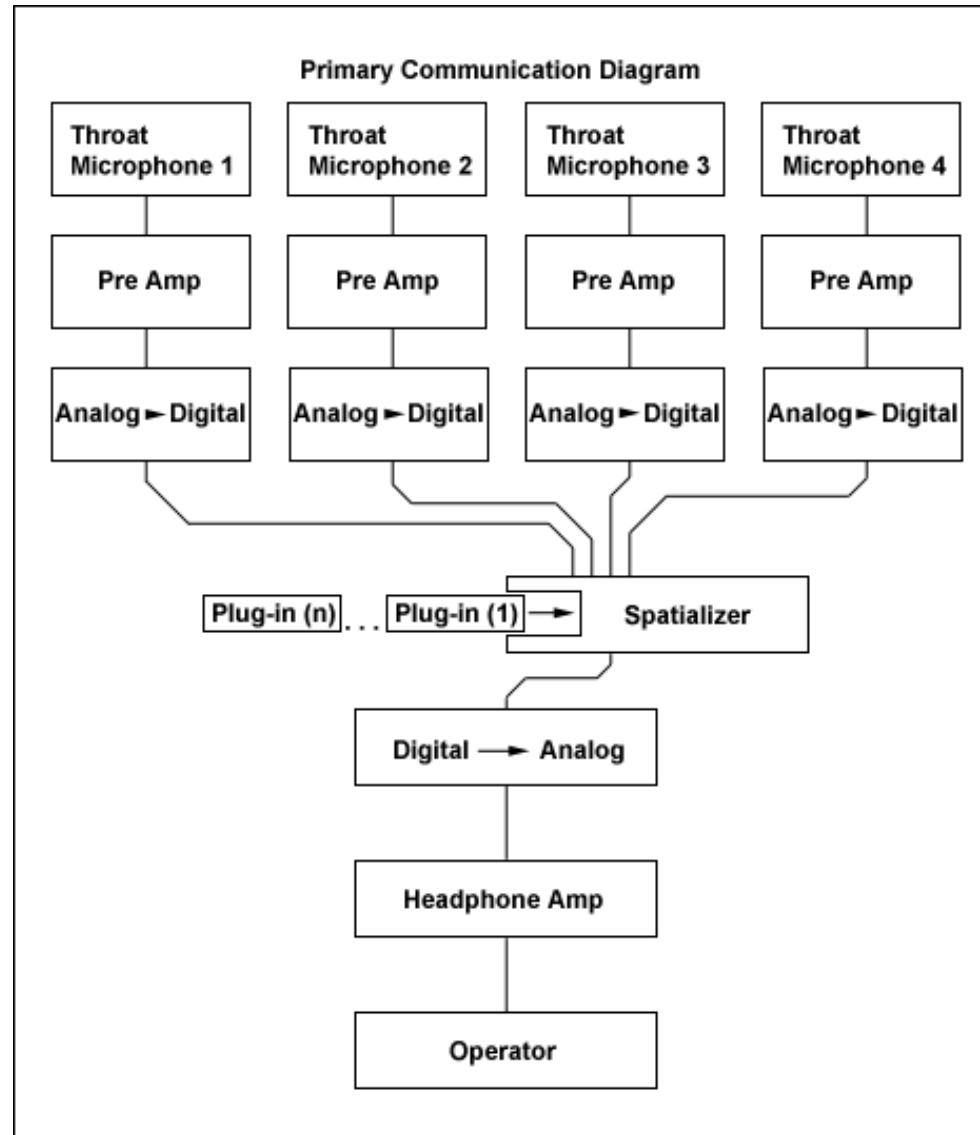

HELMET CAMERA 3-D AUDIO SYSTEM SIGNAL PATH DIAGRAM

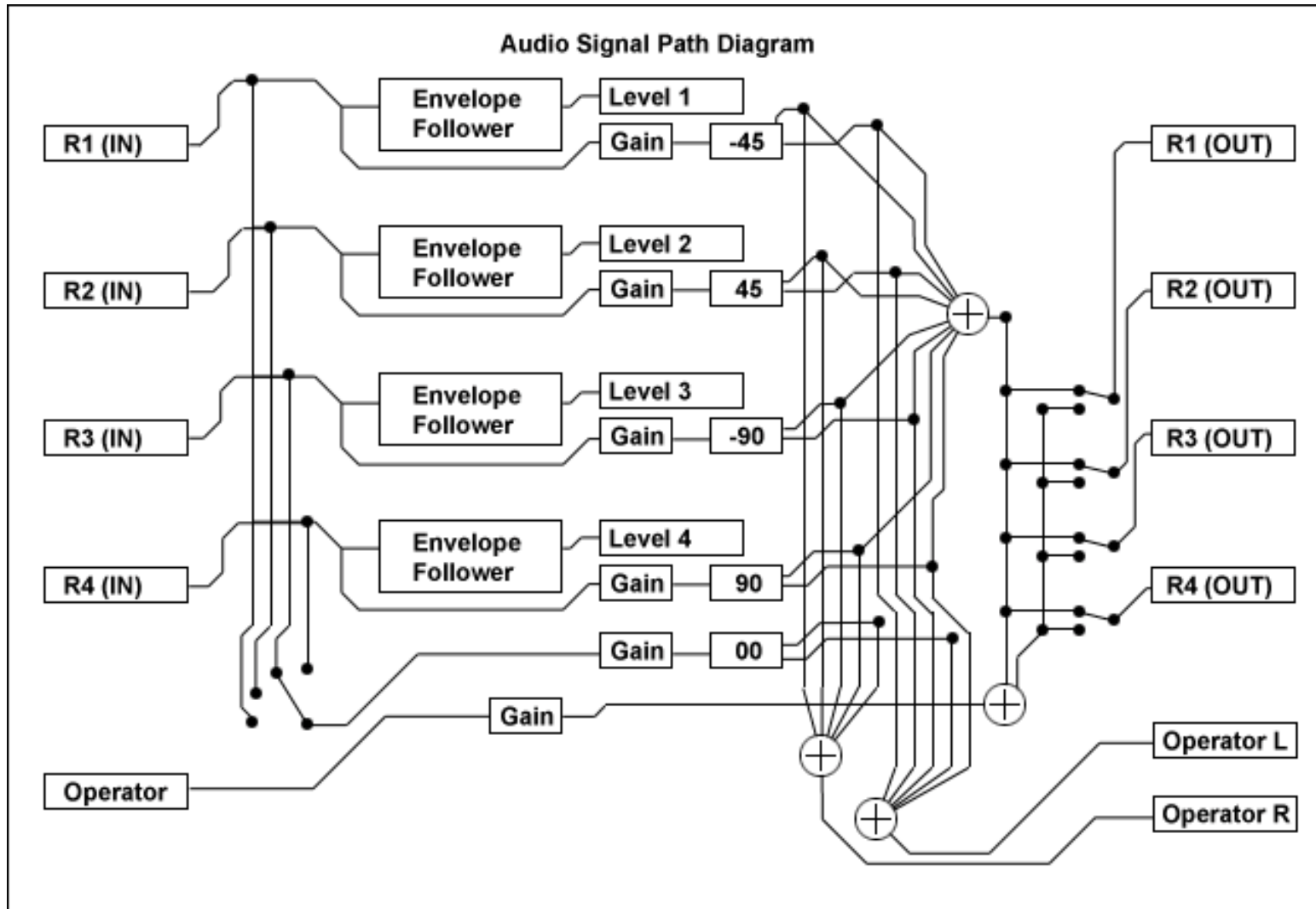

HOW DOES SPATIALIZED COMMUNICATION INCREASE SPEECH INTELLIGIBILITY?

Using binaural hearing advantage for separating multiple auditory “streams” (simultaneous sources)

Each communication channel is spatially separated.

User can use selective attention to switch between signals, as in normal hearing.

Current System

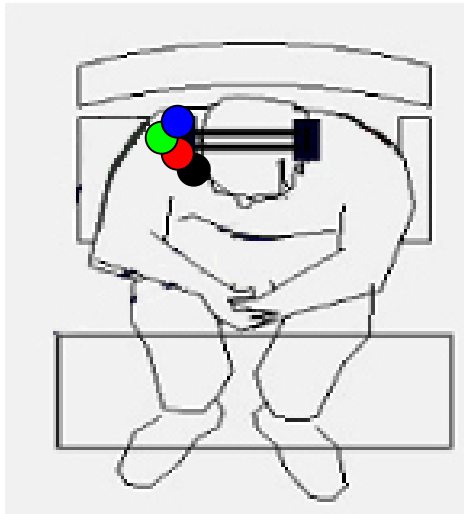

Helmet Camera System

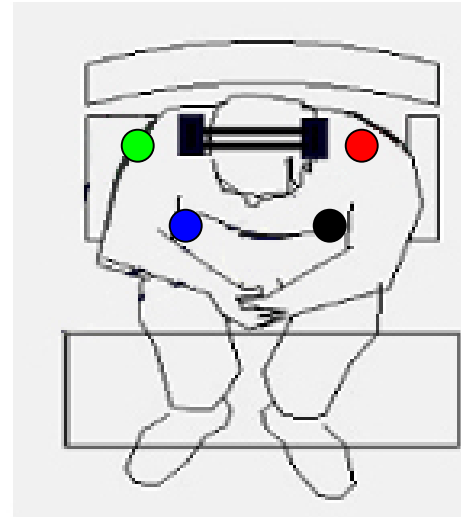

SPEECH INTELLIGIBILITY ADVANTAGE COMPARED TO ONE-EAR LISTENING

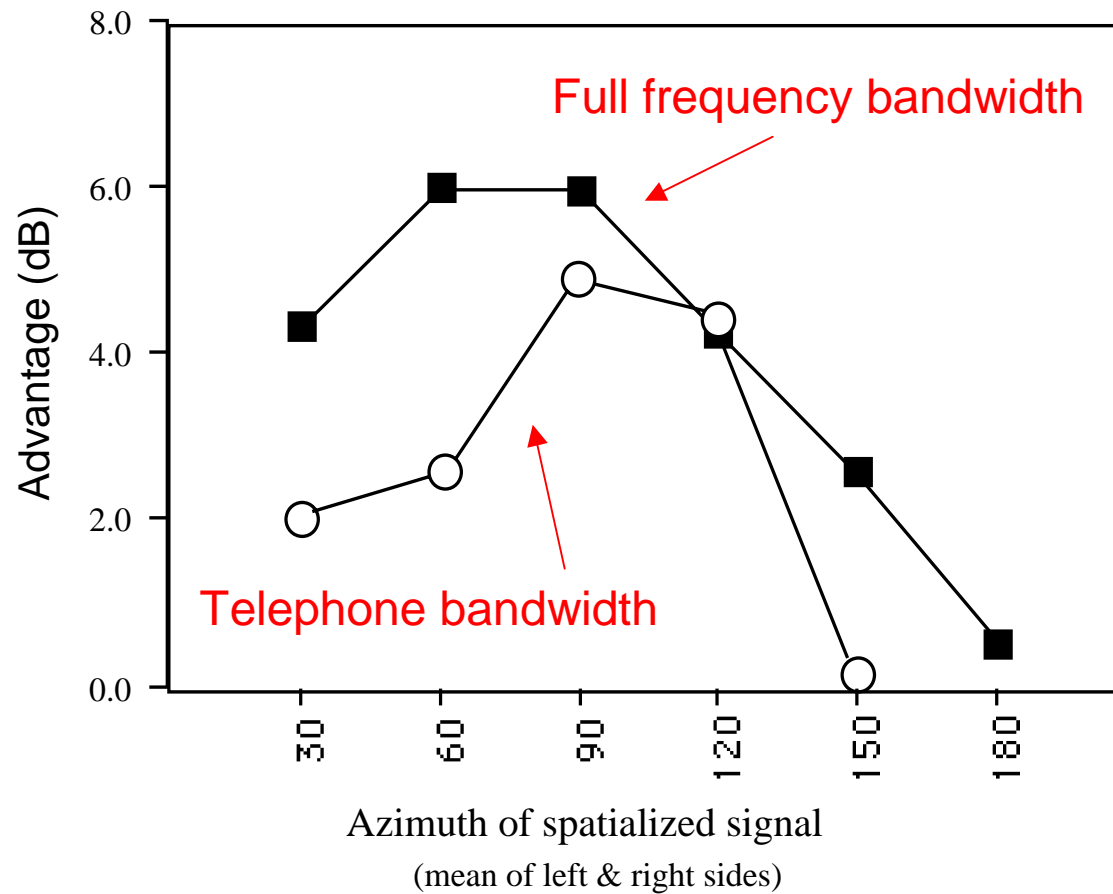



SPATIALIZED COMMUNICATION DEMO

Listen to the difference between spatialized and non-spatialized communication between crew members of a deep sea research expedition!

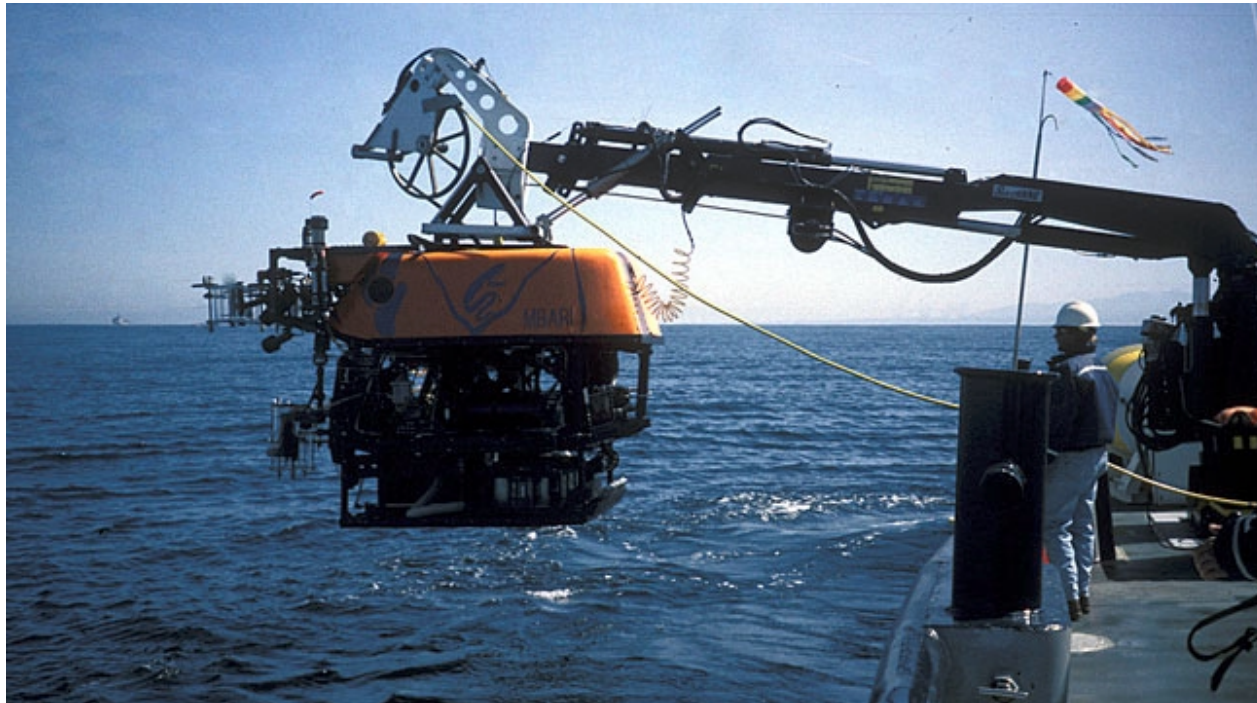

LISTEN! <http://human-factors.arc.nasa.gov/ihh/spatial/demos.html>

CONCLUSION

The Helmet Camera System developed in the Advanced Controls and Displays Lab at NASA Ames Research Center addresses the needs of rescue teams by improving audio and video communication for increased situational awareness and safety.

Current rescue communication systems used by most fire departments and search and rescue teams lack advanced features that could decrease the risk of injury for rescue workers and increase the likelihood of saving lives.

Helmet Camera's advanced technologies include spatially segregated audio streams, video feedback, front and center prioritization technology and orientation/critical data reporting.

